

Weights

Operating weight with standard bucket, excluding operator	1176 kg
Ground pressure	29.70 kPa

Engine

Make / model	Kubota / D722-E2B-BCZ-6 (TIER2)
Fuel	Diesel
Number of cylinders	3
Displacement	0.72 L
Maximum NET power (ISO 9249)	7.4 kW
Maximum NET torque (ISO 9249)	39.1 Nm

Performance

Digging force, dipperstick (ISO 6015)	5550 N
Digging force, bucket (ISO 6015)	8294 N
Drawbar pull	9905 N
Travel speed (low range)	2.1 km/h
Travel speed (high range)	3.1 km/h

Hydraulic System

Pump type	Double gear pump
Pump capacity	10.00 L/min
Auxiliary flow	20.00 L/min
Auxiliary relief	184.0-192.0 bar
Relief pressure for implement circuit	184.0-192.0 bar

Slew System

Boom swing, left	70.0°
Boom swing, right	70.0°
Slew rate	9.0 RPM

Fluid Capacities

Cooling system	3.00 L
Engine lubrication plus oil filter	3.50 L
Fuel reservoir	16.00 L
Hydraulic reservoir	2.60 L
Hydraulic system	10.10 L

Environmental

Noise level LpA(EU Directive 2006/42/EC)	80 dB(A)
Noise level LWA(EU Directive 2000/14/EC)	93 dB(A)

Standard Features

710 mm dozer blade / 1100 mm extended	Retractable seat belt
180 mm rubber track	Seat
Auxiliary hydraulics with Quick Couplers	Two-speed travel
Control console locks	TOPS canopy ¹
Horn	Vandalism protection
Electronically activated track expansion	Work lights
Hydraulically expandible undercarriage from 710 to 1100 mm	Warranty: 12 months, 2000 hours (whichever occurs first)

1. Tip Over Protective Structure (TOPS) – Meets requirements of ISO 12117

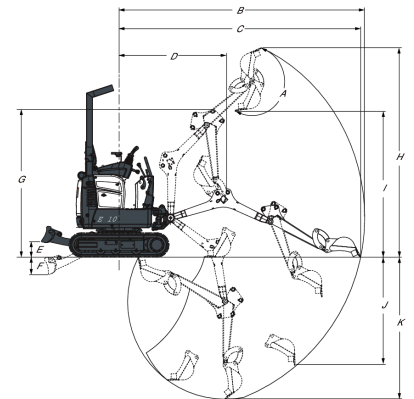
Working Range

(A) 196.0°	(G) 1899.0 mm
(B) 3145.0 mm	(H) 2685.0 mm
(C) 3093.0 mm	(I) 1818.0 mm
(D) 1374.0 mm	(J) 1383.0 mm
(E) 196.0 mm	(K) 1820.0 mm
(F) 230.0 mm	

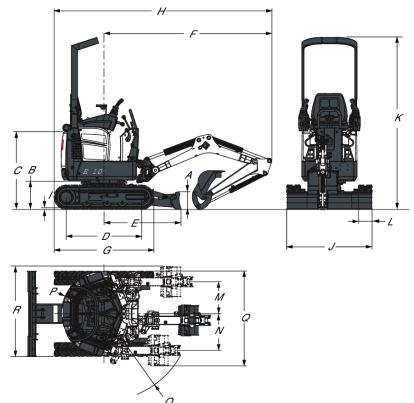
Dimensions

(A) 220.0 mm	(J) 710.0 mm
(B) 363.0 mm	(J) 1100.0 mm
(C) 992.0 mm	(K) 2209.0 mm
(D) 968.0 mm	(L) 180.0 mm
(E) 987.0 mm	(M) 413.0 mm
(F) 2153.0 mm	(N) 471.0 mm
(G) 1280.0 mm	(O) 1121.0 mm
(H) 2793.0 mm	(P) 550.0 mm
(I) 16.0 mm	

Options

Auxiliary double action	Travel motion alarm
Beacon kit	Strobe
Demolition kit	Spark arrester muffler
Keyless start	

1 Tonne Hi-Tip Hydrostatic

MACH201

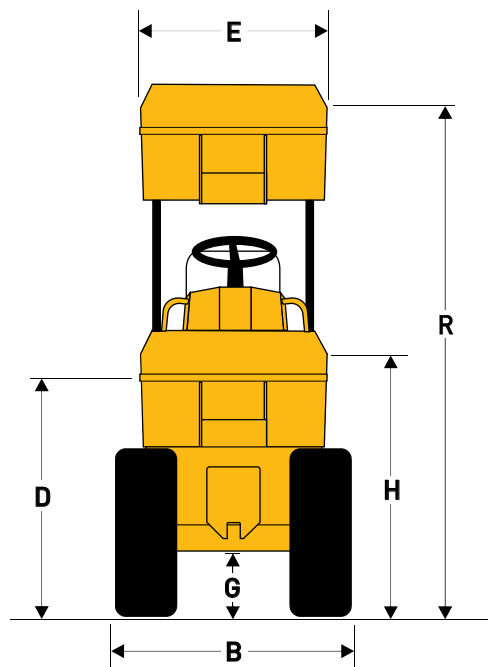
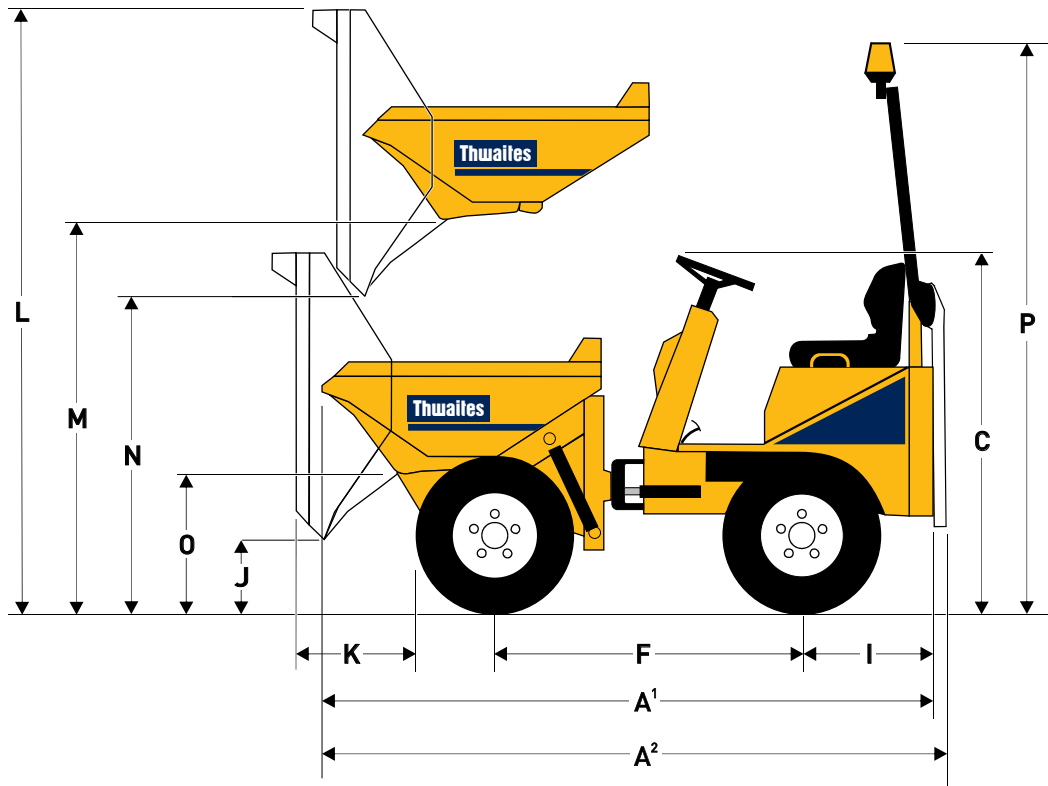

Dimensions (mm)

A ¹	3032
A ²	3192
B	1115 (982*)
C	1773
D	1155
E	982
F	1500
G	274
H	1262
I	654
J	346
K	505
L	3005
M	1913
N	1573
O	720
P	2860
R	2370

*with optional narrow wheels

1 Tonne Hi-Tip Hydrostatic

MACH201

Capacities	Max safe load	1000 kg
	Heaped	500 litres
	Struck	400 litres
	Water	280 litres

Engine

Yanmar 3TNV76, 15.9 kW/21.4 bhp (nett) @ 2800 rpm, 3-cylinder water-cooled diesel. Max torque 66.4 Nm (49 lb f ft). Electric starting, hour meter, battery isolator switch and heavyduty cyclonic air cleaner positioned within the lockable engine compartment.

Noise Levels

Operator's ear 84 LpA, airborne sound power level 101 LwA (to 2000/14/EC).

Speeds	Forward / reverse	0-12 km/h
---------------	-------------------	-----------

Tyres	Standard	Optional
	10.0/75 x 15.3	7.00 x 12
	8 Ply	6 Ply
	Track grip tread	Track grip tread

Brakes and Axles

Automatic failsafe braking system incorporated into rear drive motors.

Chassis

Front and rear chassis constructed from folded steel plate, with centre-point articulation and oscillation for optimum stability and traction.

Drive System

Hydrostatic with variable displacement pump feeding four wheel motors, incorporating "Twin-Lock" system to maximise traction.

Skip

Hydraulically operated, 3 mm base, 4 mm sides steel plate. Mouth reinforced with box sections giving greater strength to minimise damage, no material traps. Raise and tip control operated by twin control levers.

Seating & Controls

Column-mounted forward/reverse lever with foot pedal speed control. Adjustable suspension seat, accessible from both sides. Audible warning device at key start 'on' position. Super-bright warning lights for all critical functions. Electric horn.

Service Access

Lockable three-sided cover provides easy access from ground level to engine service points.

Electrics

Wiring harness contained within conduits and all electrical components water resistant to IP65/67 standards.

Steering & Hydraulics

Hydraulic power steering. Return line filtration for all services and large capacity suction strainer in the tank to give full circuit protection. Hydraulic test point fitted as standard.

Tank Capacities	Fuel	21 litres
	Hydraulic	20 litres

Shipping Cube	6.3 m ³ (with folded ROPS)
----------------------	---------------------------------------

Unladen Weight	1295 kg
-----------------------	---------

Clearance Diameter	5.45 m
---------------------------	--------

ROPS/Beacon

A folding ROPS bar and beacon are fitted as standard.

Optional EXtras

Full road lighting equipment. Reverse alarm. UK road equipment. Towing bracket. Sand tyres and narrow tyres.

Distributor

Thwaites

Thwaites Ltd. Leamington Spa, Warwickshire CV32 7NQ, England
 Tel +44 (0)1926 422471 Fax +44 (0)1926 337155
 www.thwaitesdumpers.co.uk



We reserve the right to change all specifications without prior notice.
 Printed in England 08/2017